

MICHAEL SCHMID

Transmission #15/magenta
(November 2019; Thinking of the past;
Fujicolor Crystal Archive RA-4 Color
Print Paper (Type II) 8x10/100 sheets
Lustre; In the night; Devere 5108 FS
Enlarger; I feel nervous and lonely;
Kreonite KM IV RA-4 Processor; I can't
see; Contact Photo Lab, 618 Moulton
Ave, Los Angeles, CA 90031, USA; My
hands) 2019/2020, 25x20 cm, C-Print



Transmission #4/neutral
(November 2019; The acidic smell;
Fujicolor Crystal Archive RA-4 Color
Print Paper (Type II) 8x10/100 sheets
Lustre; And random choices; Durst La-
borator 1200 CLS 501 Enlarger; Wal-
king, a rainbow; Kreonite KM IV RA-4
Processor; Above Normandie and Sunset;
Contact Photo Lab, 618 Moulton Ave,
Los Angeles, CA 90031, USA; On the way
home) 2019/2020, 25x20 cm, C-Print



Transmission #17/purple
(November 2019; Afraid of being; Fuji-
color Crystal Archive RA-4 Color Print
Paper (Type II) 8x10/100 sheets Lust-
re; In this dark space by myself; De-
vere 5108 FS Enlarger; I'm hitting my
head; Kreonite KM IV RA-4 Processor;
Constantly; Contact Photo Lab, 618
Moulton Ave, Los Angeles, CA 90031,
USA; Against something) 2019/2020,
25x20 cm, C-Print



Transmission #21/neutral
(November 2019; The city of Los Angeles; Fujicolor Crystal Archive RA-4 Color Print Paper (Type II) 8x10/100 sheets Lustre; Talented people; Devere 5108 FS Enlarger; Wandering the streets; Kreonite KM IV RA-4 Processor; Without a car; Contact Photo Lab, 618 Moulton Ave, Los Angeles, CA 90031, USA; And not alone) 2019/2020, 25x20 cm, C-Print



Transmission #36/light
(November 2019; The lonelier I feel;
Fujicolor Crystal Archive RA-4 Color
Print Paper (Type II) 8x10/100 sheets
Lustre; The more sad I become; Devere
5108 FS Enlarger; But this work; Kreo-
nite KM IV RA-4 Processor; Will never
convey it; Contact Photo Lab, 618 Moul-
ton Ave, Los Angeles, CA 90031, USA;
To you) 2019/2020, 25x20 cm, C-Print



Übersicht über das Gerät

Vorderansicht



- Die Abbildung kann je nach Modell oder Land unterschiedlich sein (siehe Funktionen nach Modell auf Seite 7).
- Einige Funktionen sind optional (siehe Bedienungsanleitung für Details).

To you
 We never convey it
 But this work
 The more sad I become
 The lonelier I feel
 And not alone
 Without a car
 Wandering the streets
 Talented people
 The city of Los Angeles

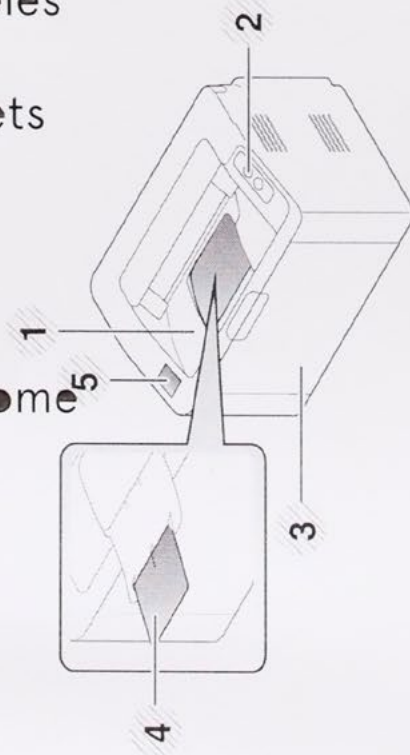

Against something
 Constantly
 I'm hitting my head
 In this dark space by myself
 Afraid of being

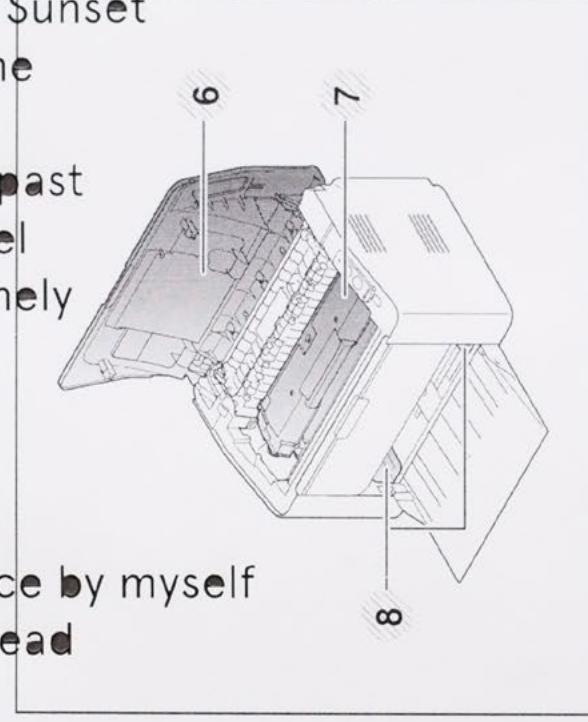

My hands
 And I can't see
 Nervous and lonely
 In the night I feel
 Thinking of the past

On the way home
 Normandy and Sunset
 Walking, a rainbow above
 And random choices
 The acidic smell
 Transmission

1	Ausgabefach	5	NFC (Near Field Communication) Registerkarte
2	Bedienfeld	6	Obere Abdeckung
3	Fach	7	Tonerkartusche
4	Ausgabehalterung	8	Papierbreitenführung

Transmission
 (Samsung SL-M2020, SEC8425199908AC),
 2020, 29,7x21cm, Laserjet and pencil
 on PlanoArt hochfein, holzfrei 90g

das Gerät

On the way home

Thinking of the past

In the night I feel

Nervous and lonely

And I can't see

My hands

Afraid of being

In this dark space by myself

I'm hitting my head

Constantly

Against something

The city of Los Angeles

Talented people

Wandering the streets



Transmission
(Samsung SL-M2020, SEC8425199908AC),
2020, 29,7x21cm, Laserjet and pencil
on PlanoArt hochfein, holzfrei 90g

detail

Michael Schmid
© VG Bildkunst, Bonn 2020